

## Power line chokes

Current-compensated ring core double chokes  
250 V AC, 18 A, 1.3 mH

**Series/Type:** B82726S2183N020

**Date:** July 2012

© EPCOS AG 2015. Reproduction, publication and dissemination of this publication, enclosures hereto and the information contained therein without EPCOS' prior express consent is prohibited.

EPCOS AG is a TDK Group Company.

**Current-compensated ring core double chokes****Rated voltage 250 V AC****Rated current 18 A****Rated inductance 1.3 mH****Construction**

- Current-compensated ring core double choke
- Ferrite core
- Epoxy base plate (UL 94 V-0)
- Choke fixed with PU compound (UL 94 V-0)
- Sector winding
- Clearance 2.5 mm, creepage distance 3.0 mm

**Features**

- Approx. 1% stray inductance for symmetrical interference suppression
- Suitable for wave soldering
- Design complies with EN 60938-2 (VDE 0565-2)
- RoHS-compatible

**Applications**

- Suppression of common-mode interferences
- Switch-mode applications

**Terminals**

- Ends of winding wires
- Hot-dip tinned

**Marking**

Manufacturer, ordering code, rated current, rated voltage, rated inductance, date of manufacture (MM.YY)

**Delivery mode**

Cardboard box

## Current-compensated ring core double chokes

## Dimensional drawing and pin configuration

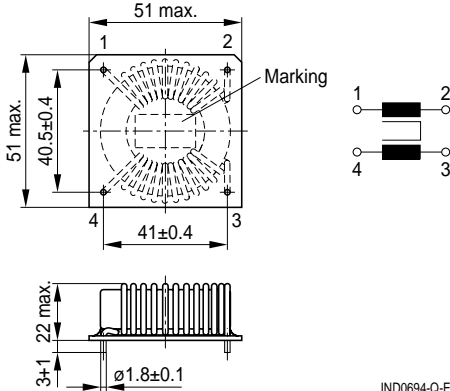

IND0694-Q-E

Dimensions in mm

## Technical data and measuring conditions

|   |   |
|---|---|
| Rated voltage $V_R$                           | 250 V AC (50/60 Hz)   |
| Test voltage $V_{test}$                       | 1500 V AC / 2100 V DC, 2 s (line/line)  |
| Rated temperature $T_R$                       | +50 °C  |
| Rated current $I_R$                           | Referred to 50 Hz and rated temperature   |
| Rated inductance $L_R$                        | Measured with Agilent 4284A at 10 kHz, 0.1 mA, +20 °C<br>Inductance is specified per winding.             |
| Inductance tolerance                          | 30% at +20 °C   |
| Inductance decrease $L/L_0$                   | < 10% at DC magnetic bias with $I_R$ , +20 °C   |
| Stray inductance $L_{stray,typ}$              | Measured with Agilent 4284A at 10 kHz, 5 mA, +20 °C, typical value  |
| DC resistance $R_{typ}$                       | Measured at +20 °C, typical value, specified per winding  |
| Solderability (lead-free)                     | Sn96.5Ag3.0Cu0.5: +(245 5) °C, (3 0.3) s<br>Wetting of soldering area 95%<br>(to IEC 60068-2-20, test Ta) |
| Resistance to soldering heat (wave soldering) | +(260 5) °C, (10 1) s<br>(to IEC 60068-2-20, test Tb)   |
| Climatic category                             | 40/125/56 (to IEC 60068-1)  |
| Storage conditions (packaged)                 | -25 °C ... +40 °C, 75% RH   |
| Weight  | Approx. 85 g  |



## Cautions and warnings

- Please note the recommendations in our Inductors data book (latest edition) and in the data sheets.
  - Particular attention should be paid to the derating curves given there. Derating must be applied in case the ambient temperature in the application exceeds the rated temperature of the component.
  - Ensure the operation temperature (which is the sum of the ambient temperature and the temperature rise caused by losses / self-heating) of the component in the application does not exceed the maximum value specified in the climatic category.
  - The soldering conditions should also be observed. Temperatures quoted in relation to wave soldering refer to the pin, not the housing.
- If the components are to be washed varnished it is necessary to check whether the washing varnish agent that is used has a negative effect on the wire insulation, any plastics that are used, or on glued joints. In particular, it is possible for washing varnish agent residues to have a negative effect in the long-term on wire insulation.  
Washing processes may damage the product due to the possible static or cyclic mechanical loads (e.g. ultrasonic cleaning). They may cause cracks to develop on the product and its parts, which might lead to reduced reliability or lifetime.
- The following points must be observed if the components are potted in customer applications:
  - Many potting materials shrink as they harden. They therefore exert a pressure on the plastic housing or core. This pressure can have a deleterious effect on electrical properties, and in extreme cases can damage the core or plastic housing mechanically.
  - It is necessary to check whether the potting material used attacks or destroys the wire insulation, plastics or glue.
  - The effect of the potting material can change the high-frequency behaviour of the components.
- Ferrites are sensitive to direct impact. This can cause the core material to flake, or lead to breakage of the core.
- Even for customer-specific products, conclusive validation of the component in the circuit can only be carried out by the customer.

